

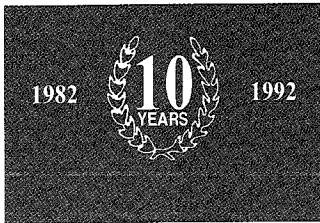

SPROMAK[®] LTD.

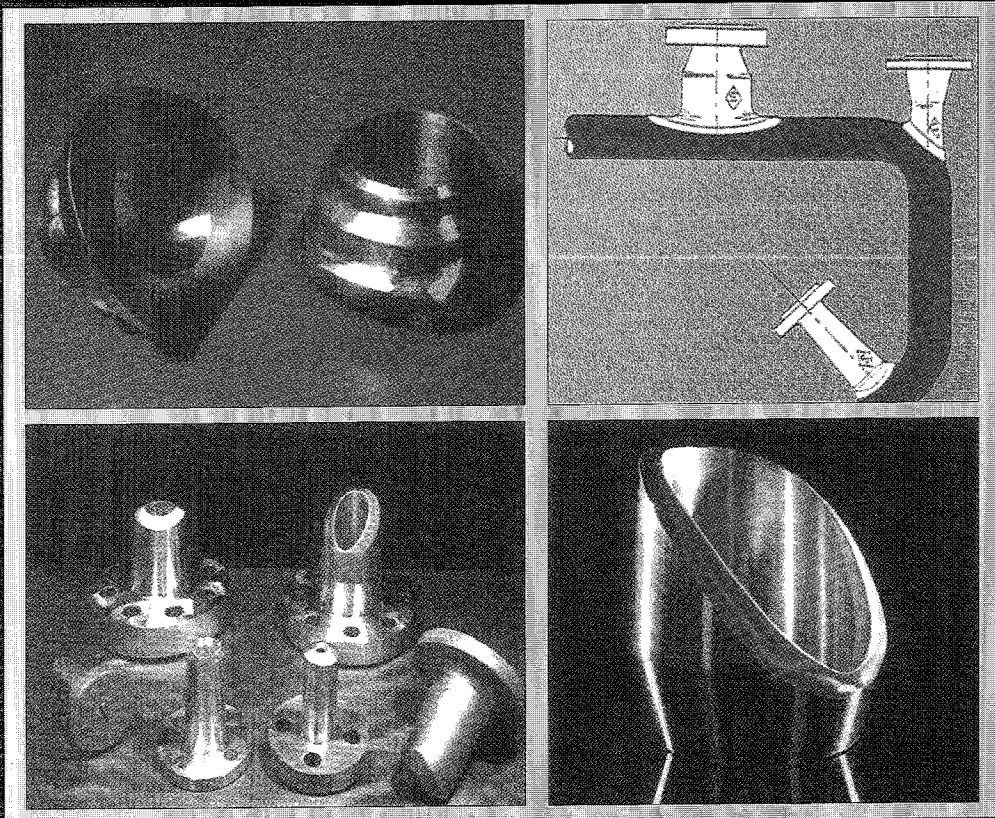

- MANUFACTURERS OF
- FLANGED BUTTWELD OUTLET[®]
 - FLANGED NIPPLE OUTLET[®]
 - FLANGED LATERAL OUTLET[®]
 - FLANGED ELBOW OUTLET[®]
 - FLANGED INSERT OUTLET[®]
 - BUTTWELD OUTLETS[®]
 - SOCKETWELD OUTLETS[®]
 - THREADED OUTLETS[®]
 - NIPPLE OUTLETS[®]
 - LATERAL OUTLETS[®]
 - ELBOW OUTLETS[®]
 - INSERT BRANCH OUTLETS[®]



SPROMAK[®]
LTD.

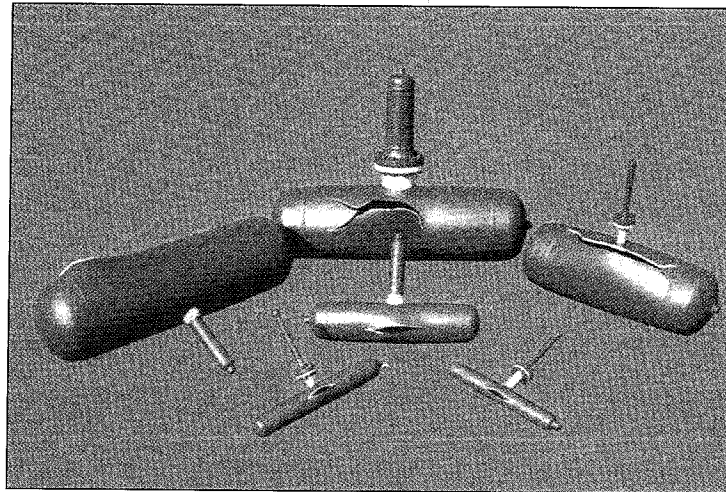

Some examples of Proof Burst Tests

Spromak Ltd® introduce their range of reinforced branch outlet fittings for pipe line pressure vessel application. BUTTWELD OUTLET, NIPPLE OUTLET, SOCKETWELD OUTLET, LATERAL OUTLET and THREADED OUTLET are designed to give integral reinforcement, added flow characteristics and stress distribution.

The company manufactures its forged steel branch outlet fittings from 1/4in. nominal bore upwards, to make full size and reduced size connections. They are produced as:

BUTTWELD OUTLETS, SOCKETWELD OUTLETS, THREADED OUTLETS, NIPPLE OUTLETS and LATERAL OUTLETS. Full test data and proof calculations are available on request.

These fittings are designed to meet design requirements of reinforced branch connections to the following specifications: ASME/ANSI B31.1 USA Standard Code for pressure piping, power piping.

ASME/ANSI B16.9 USA Standard for steel butt welding fittings
BS.5500 British Standard specification for fusion welded pressure vessels.

ASME Boiler and pressure vessel codes section I and section VIII Div. 1 and 2.

ASME/ANSI B31.3 USA Standard Code for pressure piping, chemical plant and petroleum refinery piping.

BUTTWELD OUTLETS, SOCKETWELD OUTLETS, THREADED OUTLETS are manufactured by SPROMAK LIMITED® in its modern and fully equipped factory at Liverpool. The company offers full design facilities and expert advice on any aspect of reinforced branch connections.

Inspection by the quality control department ensures the high standard of manufacture in day to day production is maintained. All fittings are fully certified and identified numerically.

For any additional information, quotations, or advice, contact:
SPROMAK LIMITED®, 11G Wilson Road, Huyton, Liverpool
L36 6AN, England. Telephone: 0151-480 0592.
Fax: 0151-480 0656. E-Mail: sales@spromak.co.uk
Website: www.spromak.co.uk



CERTIFICATE OF APPROVAL

This is to certify that the Quality Management System of:

***Spromak Ltd
Huyton, Liverpool
United Kingdom***

*has been approved by Lloyd's Register Quality Assurance
to the following Quality Management System Standards:*

BS EN ISO 9001:2000

The Quality Management System is applicable to:

Manufacture of branch outlet pipe fittings.

Approval

Certificate No: LRQ 0870517

Original Approval: 30 October 1990

Current Certificate: 9 July 2003

Certificate Expiry: 30 September 2005

Issued by: LRQA Coventry



001

This document is subject to the provision on the reverse

*This approval is carried out in accordance with the LRQA assessment and certification procedures and monitored by LRQA.
The use of the UKAS Accreditation Mark indicates Accreditation in respect of those activities covered by the Accreditation Certificate Number 001
Macro Revision 10.1*



DIMENSIONS UNIFICATION

In order to reduce warehouse inventory, our outlets have been unified to fit on different run-pipe sizes with gap maximum of 1/32" between the run-pipe and outlet. This does not cause any problems during welding.

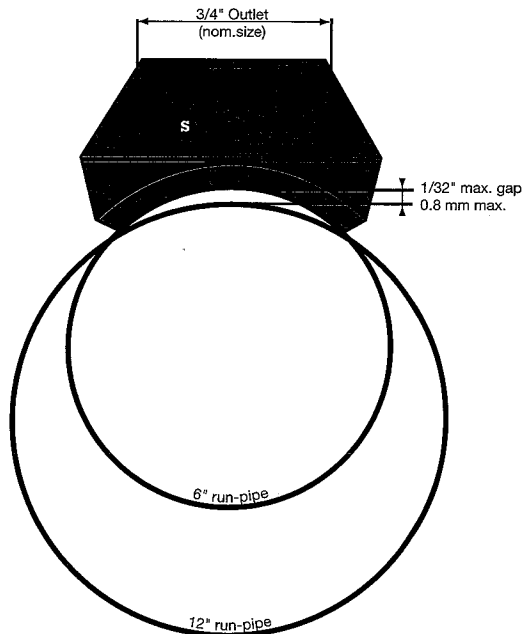

BUTTWELD-OUTLETS STANDARD AND EXTRA STRONG SOCKET-OUTLETS & THREADED-OUTLETS 3000 LBS.

OUTLET SIZE	RUN-PIPE SIZES									
1/2	1/2	3/4	1	1 1/2-1 1/4	2 1/2-2	8-3	36-10			
3/4	3/4	1	1 1/2-1 1/4	2 1/2-2	5-3	12-6	36-14			
1	1	1 1/4	1 1/2	2	2 1/2	3 1/2-3	5-4	10-6	36-12	
1 1/4	1 1/4	1 1/2	2	2 1/2	3 1/2-3	5-4	8-6	18-10	36-20	
1 1/2	1 1/2	2	2 1/2	3	4-3 1/2	6-5	12-8	24-14	36-26	
2	2	2 1/2	3	3 1/2	4	5	6	10-8	18-12	36-20
2 1/2	2 1/2	3	3 1/2	4	5	6	8	12-10	18-14	36-20
3	3	3 1/2	4	5	6	8	10	14-12	20-16	36-24
3 1/2	3 1/2	4	5	6	8	10	14-12	20-16	36-24	
4	4	5	6	8	10	14-12	20-16	36-24		

Outlet over 4" order to specific run-pipe size BUTTWELD-OUTLETS SCH. 160 AND XXS

OUTLET SIZE	RUN-PIPE SIZES								
1/2	1/2	1 1/4-3/4	36-1 1/2						
3/4	1-3/4	2-1 1/4	6-2 1/2	36-8					
1	1	2 1/2-1 1/4	10-3	36-12					
1 1/4	1 1/2-1 1/4	2 1/2-2	10-3	36-12					
1 1/2	1 1/2	2 1/2-2	3 1/2-3	8-4	20-10	36-24			
2	2	2 1/2	3 1/2-3	5-4	8-6	18-10	36-20		

Outlets over 2" order to specific run-pipe size SOCKETWELD-OUTLETS & THREADED-OUTLETS 6000 LBS.

OUTLET SIZE	RUN-PIPE SIZES								
1/2	1-3/4	2-1 1/4	6-2 1/2	36-8					
3/4	1	2 1/2-1 1/4	10-3	36-12					
1	1 1/4-1 1/2	2 1/2-2	10-3	36-12					
1 1/4	1 1/2	2 1/2-2	3 1/2-3	8-4	20-10	36-24			
1 1/2	2	2 1/2	3 1/2-3	5-4	8-6	18-10	36-20		
2	2 1/2	3	4	5	6	10-8	20-12	36-24	

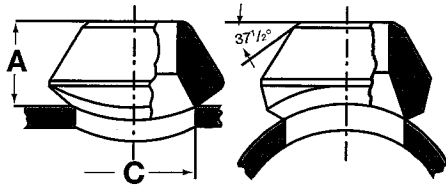

REDUCING SIZE

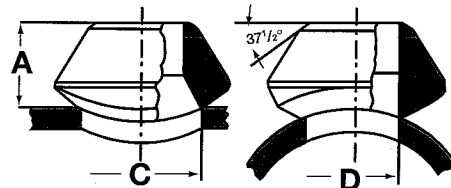

FULL SIZE

Butt Weld Outlets • STANDARD

OUTLET SIZE	REDUCED SIZES			FULL SIZES			
	A	C	Approx Weight	A	C	D	Approx. Weight
1/2	19.00	24.00	0.08	19.00	24.00	15.80	0.07
3/4	22.20	30.00	0.11	22.20	30.00	21.00	0.11
1	27.00	36.50	0.25	27.00	36.50	26.60	0.18
1 1/4	31.50	44.50	0.35	31.50	44.50	35.00	0.32
1 1/2	33.40	51.00	0.45	33.40	51.00	40.90	0.36
2	38.00	65.00	0.80	38.00	65.00	52.50	0.68
2 1/2	41.20	76.15	1.13	41.20	76.15	62.80	1.02
3	44.50	93.50	1.82	44.50	93.50	78.00	1.70
3 1/2	47.50	112.60	2.50	47.50	112.60	90.20	2.30
4	51.00	120.50	2.86	51.00	120.50	102.20	3.10
5	57.00	141.30	4.65	57.00	141.30	128.20	3.90
6	60.30	170.00	6.45	60.30	170.00	154.00	6.70
8	69.80	220.50	10.66	69.80	220.50	202.50	13.00
10	78.00	274.00	18.00	78.00	274.00	254.00	16.00
12	86.00	324.00	27.00	86.00	324.00	304.50	27.00
14	89.00	356.00	30.00	89.00	356.00	336.50	32.00
16	94.00	406.00	34.00	94.00	406.00	387.00	42.00
18	97.00	459.00	44.00	103.00	473.00	438.00	57.00
20	102.00	508.00	54.00	117.00	508.00	489.00	80.00
24	144.00	609.00	101.00	144.00	609.00	590.00	114.00
26	156.00	660.00	120.00	156.00	660.00	641.00	138.00
30	175.00	762.00	190.00	175.00	762.00	743.00	230.00
36	206.00	914.00	310.00	206.00	914.00	895.00	336.00

Butt Weld Outlets • EXTRA STRONG

OUTLET SIZE	REDUCED SIZES			FULL SIZES			
	A	C	Approx Weight	A	C	D	Approx. Weight
1/2	19.00	24.00	0.09	19.00	24.00	13.90	0.07
3/4	22.20	30.00	0.14	22.20	30.00	18.90	0.11
1	27.00	36.50	0.21	25.40	36.50	24.30	0.18
1 1/4	31.50	44.50	0.41	28.50	44.50	32.80	0.32
1 1/2	33.40	51.00	0.50	31.50	51.00	38.10	0.41
2	38.00	65.00	0.80	38.00	65.00	49.30	0.75
2 1/2	41.20	76.15	1.18	41.20	76.15	59.00	1.15
3	44.50	93.50	1.90	44.50	93.50	73.70	1.90
3 1/2	47.50	112.60	2.55	47.50	112.60	85.40	2.30
4	51.00	120.50	3.00	51.00	120.50	97.20	3.50
5	57.00	141.30	4.75	57.00	141.30	122.30	4.32
6	78.00	170.00	10.50	78.00	170.00	146.30	6.80
8	98.50	220.00	17.00	98.50	220.00	194.00	14.60
10	94.00	265.00	21.00	95.30	265.00	247.50	21.00
12	103.00	316.00	28.00	100.00	320.00	298.00	28.00
14	100.00	351.00	32.00	105.50	355.00	330.00	34.50
16	106.50	403.00	46.50	113.00	419.00	381.00	52.50
18	111.00	456.00	59.00	119.00	474.00	432.00	59.00
20	119.00	510.00	72.00	127.00	528.50	482.50	85.00
24	152.00	610.00	142.00	152.00	610.00	584.20	146.00
26	165.00	660.00	168.00	165.00	660.00	635.00	182.00
30	181.00	762.00	218.00	181.00	762.00	738.00	255.00
36	212.50	914.00	404.00	212.00	914.00	889.00	446.00

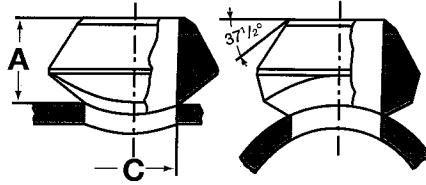

REDUCING AND FULL SIZE

Butt Weld Outlets • SCH. 160 AND XXS

OUTLET SIZE	REDUCING SIZES			FULL SIZES		
	A	C	Approx. Weight	A	C	Approx. Weight
1/2	28.50	14.30	0.110	28.50	14.30	0.110
3/4	31.50	19.00	0.320	31.50	19.00	0.320
1	38.00	25.50	0.380	38.00	25.50	0.380
1 1/4	44.50	33.40	0.570	44.50	33.40	0.570
1 1/2	50.70	38.00	0.800	50.70	38.00	0.800
2	55.50	42.90	1.00	55.50	42.90	1.00
2 1/2	61.80	53.90	1.550	61.80	53.90	1.550
3	73.00	73.00	2.900	73.00	73.00	2.900
4	84.00	98.40	4.770	84.00	98.40	4.770
5	93.50	122.20	6.470	93.50	122.20	6.470
6	104.70	146.00	12.80	104.70	146.00	13.80

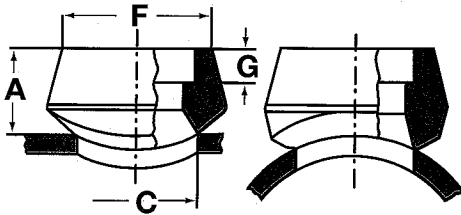

REDUCING SIZE

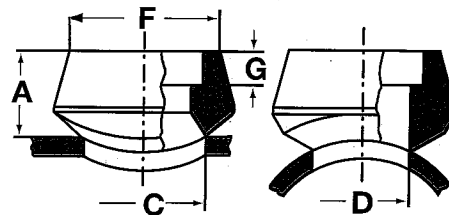

FULL SIZE

Socket Weld Outlets • 3000 LBS (SOCKET WELD TO ASME/ANSI B16.11)

OUTLET SIZE	REDUCING SIZES					FULL SIZES					
	A	C	F	G	Approx. Weight	A	C	D	F	G	Approx. Weight
1/2	25.50	24.00	31.80	10.00	0.140	25.50	22.40	16.00	31.80	10.00	0.060
3/4	27.00	30.00	36.60	13.00	0.150	27.00	30.00	21.00	36.60	13.00	0.110
1	33.40	36.50	46.10	13.00	0.300	33.40	36.50	26.70	46.10	13.00	0.300
1 1/4	33.40	44.50	55.60	13.00	0.400	33.40	44.50	35.00	55.60	13.00	0.300
1 1/2	34.80	51.00	62.00	13.00	0.470	34.80	51.00	40.90	62.00	13.00	0.400
2	38.00	65.00	74.70	16.00	0.730	38.00	65.00	52.50	74.70	16.00	0.630
2 1/2	46.00	76.15	87.40	16.00	1.250	46.00	76.15	62.80	87.40	16.00	1.030
3	50.70	93.50	104.80	16.00	1.720	50.70	93.50	77.90	104.80	16.00	1.700
3 1/2	53.80	101.50	122.30	19.00	1.950	53.30	112.75	90.10	117.50	19.00	1.950
4	57.00	120.50	130.20	19.00	3.300	55.50	127.00	102.20	130.20	19.00	3.000

Socket Weld Outlets • 6000 LBS (SOCKET WELD TO ASME/ANSI B16.11)

OUTLET SIZE	REDUCING SIZES				
	A	C	F	G	Approx. Weight
1/2	31.50	19.00	40.00	10.00	0.250
3/4	36.50	25.50	46.00	13.00	0.370
1	39.60	33.40	57.20	13.00	0.600
1 1/4	41.00	38.00	65.10	13.00	0.750
1 1/2	42.70	49.30	76.30	13.00	0.920
2	52.10	70.00	92.10	16.00	2.350

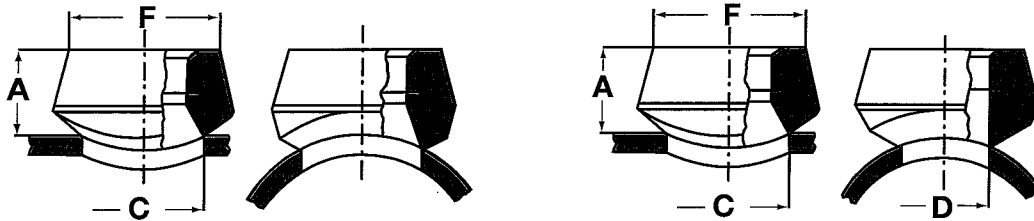

REDUCING SIZE

FULL SIZE

Threaded Outlets • 3000 lbs

OUTLET SIZE	REDUCING SIZES				Approx. Weight	FULL SIZES					
	A	C	F			A	C	D	F		
1/2	25.50	24.00	31.80		0.110	25.50	24.00	16.00	31.80		0.070
3/4	27.00	30.00	36.60		0.160	27.00	30.00	20.65	36.60		0.110
1	33.40	36.50	46.10		0.300	33.40	36.50	27.00	46.10		0.200
1 1/4	33.40	44.50	55.60		0.410	33.40	44.50	34.90	55.60		0.320
1 1/2	34.80	51.00	62.00		0.450	34.80	51.00	41.20	62.00		0.410
2	38.00	65.00	74.70		0.800	38.00	65.00	52.40	74.70		0.650
2 1/2	46.00	76.15	87.40		1.370	46.00	76.15	63.50	87.40		1.130
3	50.70	93.50	104.80		2.000	50.70	93.50	77.80	104.80		1.950
3 1/2	53.80	101.50	122.30		2.610	53.30	112.75	90.50	117.50		2.050
4	57.00	120.50	130.20		3.230	55.50	120.50	103.20	130.20		3.090

Threaded Outlets • 6000 lbs

OUTLET SIZE	REDUCING SIZES				Approx. Weight
	A	C	F		
1/2	31.50	19.00	40.00		0.200
3/4	36.50	25.50	46.00		0.350
1	39.60	33.40	57.20		0.600
1 1/4	41.00	38.00	65.10		0.710
1 1/2	42.70	49.30	76.30		0.900
2	52.10	70.00	92.10		2.300

Nipple Outlets • (PLAIN END • THREADED END & BEVEL END)

OUTLET SIZE	REDUCING SIZES			
	3000 Lbs		6000 Lbs	
	A	C	A	C
1/2	89	24	89	14.5
3/4	89	30	89	19.0
1	89	36.5	89	25.5
1 1/4	89	44.5	89	33.4
1 1/2	89	51	89	38.0
2	89	65	89	43

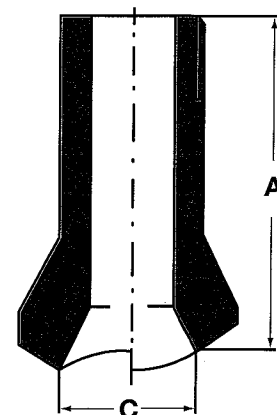



SPROMAK LTD®

INSERT BRANCH OUTLETS

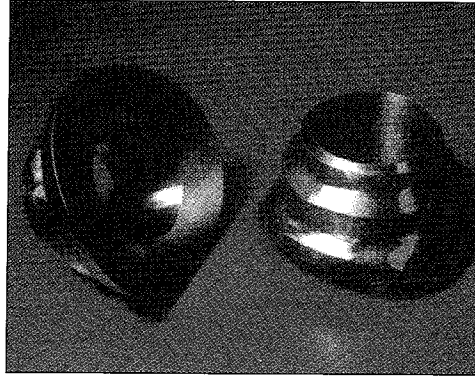

SPROMAK LTD® are the manufacturers of the INSERT BRANCH OUTLET. A header is weakened when an opening is created to install a branch outlet fitting, it could result in extra reinforcement being required to restore the strength of the opening. This is why the INSERT BRANCH OUTLETS are designed to provide a 100% reinforcement. The reinforcement design of the INSERT BRANCH OUTLET enables shorter installation time and most importantly the benefits of radiograph or ultrasonic examination after fabrication.

DESIGN CODES

Insert Branch Outlets can be supplied to comply with various piping and pressure vessel codes such as ASME/ANSI B31.1, B31.3, BS1.4, B31.8, Stoomwezen, BS5500, ASME Section 1, Section VIII div 1 & 2 and many more.

Reinforcement design calculations can be supplied on request.

STRESS

Detailed calculations for stress intensification factors or stress indices can be supplied on request on all sizes.

PROOF TESTS

The Insert Branch Outlet has undergone proof testing to ASME/ANSI B16.9 to prove the design integrity.

Custom made Insert Branch Outlets with extended "A" heights suitable for inserting into dished or hemispherical ends, etc, can be produced to suit customer's requirements.

A variant of this fitting, the FLANGED INSERT OUTLET is also manufactured on a made to order basis with specific dimensional data made available against specific enquiry only at present.

The Insert Branch Outlet is the latest addition to the extensive range of piping and pressure vessel fittings manufactured by Spromak Limited. This fitting has been developed to meet the requirements of industry for the good quality insert type branch fitting that is an economical alternative to:-

- a) Welding tees used in piping systems and
- b) Special nozzles used in pressure vessels.

Here are some of the advantages offered by the Insert Branch Outlet:-

- a) Easy to perform and readily interpretable radiography of both attachments welds.
- b) Branch reinforcements to give 100% strength.
- c) Available in any Branch size, wall thickness or metallic material.
- d) Complies with most piping and pressure vessel codes for area replacements.
- e) The exterior and interior shape provides excellent distribution of stresses and gives good internal flow characteristics
- f) Easy and economical to install, with minimum amount of weld metal required to complete an effective branch connection.

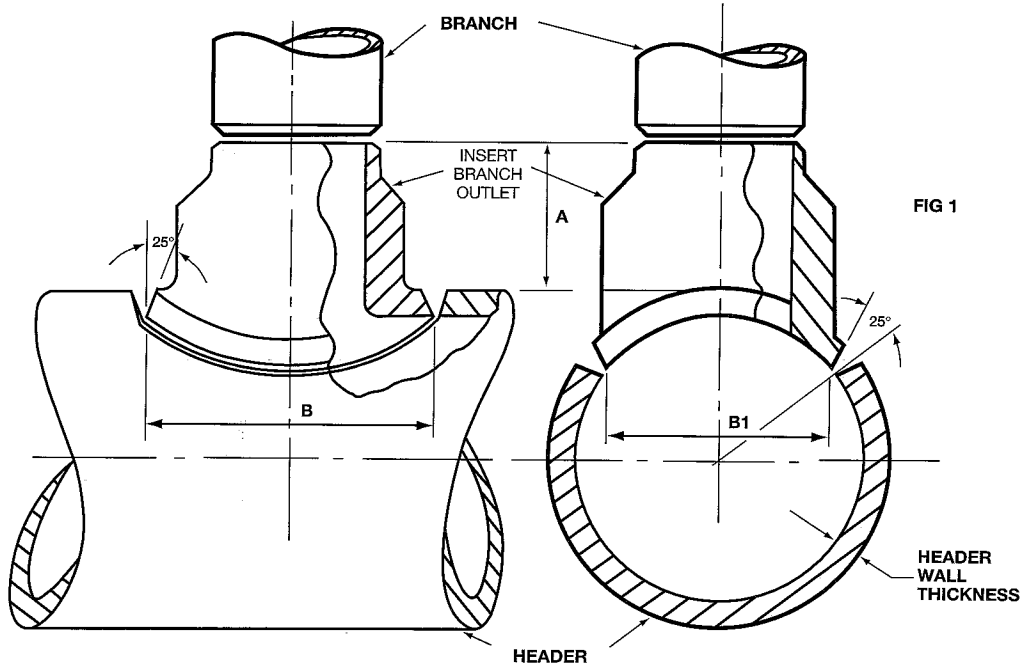

FIG 1

The following table gives the range of Header and Branch sizes covered by INSERT BRANCH OUTLETS for use with header wall thicknesses up to and including XS.*

INSERT BRANCH OUTLET DIMENSIONS UP TO AND INCLUDING XS HEADER					
BRANCH OUTLET N.B.	MIN. HEADER** N.B.	DIMENSIONS			APPROXIMATE WEIGHT - Kg
		A	B, B1 ETC		
1/2	1 1/2	1 1/4	32		.36
3/4	2	1 1/4	32		.45
1	2	1 1/4	32		.50
1 1/4	2	1 1/4	32		.59
1 1/2	2 1/2	1 1/2	38		.80
2	3	1 3/4	44		1.50
3	4	2	51	SIZES	3.10
4	6	2 3/8	60	AVAILABLE	5.5
6	8	2 11/16	68	ON	11.0
8	10	3	76	REQUEST	20.0
10	12	3 1/8	79		29.0
12	16	3 3/8	86		44.6
14	18	3 5/8	92		55.6
16	20	3 3/4	95		64.4
18	22	4 3/8	117		80.0
20	24	5 1/8	130		94.4
24	30	5 3/8	143		142.0

* Dimensions for use with header wall thicknesses heavier than XS are available on request.

** There is no limit to the maximum header size for Insert Buttweld Outlets

Elbow Outlets

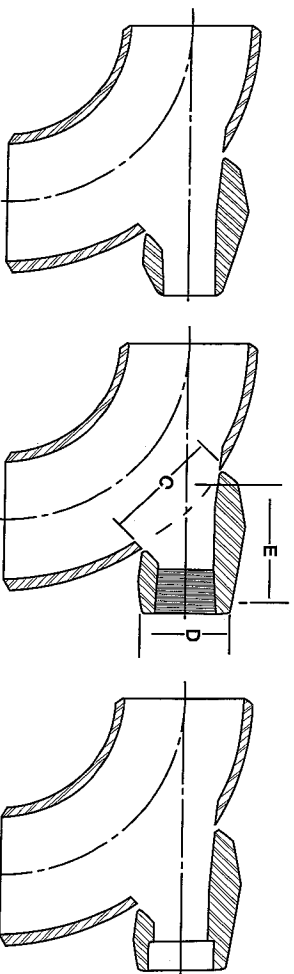

Dimensions for all three styles are the same except for the "D" dimension on the butt welding outlet which matches the proper schedule on the branch pipe.

3000 LBS THREADED AND SOCKETWELD Standard and Extra Strong Butt-weld

Nominal Elbow Size Inches	Outlet Size Inches	DIMENSIONS						Approx. Wt. lbs.	Kg.
		C	D	E	in	mm	mm		
36-1 1/4	1/4	1 1/2	38.1	1 1/4	31.8	1 1/2	38.1	0.50	0.23
36-1 1/4	3/8	1 1/2	38.1	1 1/4	31.8	1 1/2	38.1	0.50	0.23
36-1 1/4	1/2	1 1/2	38.1	1 1/4	31.8	1 1/2	38.1	0.65	0.30
36-1 1/4	3/4	1 1/2	38.1	1 1/4	31.8	1 1/2	38.1	0.75	0.34
36-2	1	1 1/4	54.0	1 29/32	45.2	2 1/16	52.4	1.15	52
36-2	1 1/4	2 1/8	73.0	2 9/32	54.8	2 3/16	55.6	1.90	86
36-2	1 1/2	3 1/8	79.4	2 1/2	63.5	2 5/16	58.8	2.65	1.20
36-3	2	4 3/16	106.4	3 1/4	82.6	2 3/4	69.9	5.25	2.39

DIMENSIONS ON APPLICATION

Order	4	3
to Specific Elbow	6	8
Sizes	10	12

6000 LBS THREADED AND SOCKETWELD Schedule 160 and Double Extra Strong Butt-weld

Nominal Elbow Size Inches	Outlet Size Inches	DIMENSIONS						Approx. Wt. lbs.	Kg.
		C	D	E	in	mm	mm		
36-1 1/4	1/4	1 1/2	38.1	1 1/4	31.8	1 1/2	38.1	0.75	0.34
36-1 1/4	3/8	1 1/2	38.1	1 1/4	31.8	1 1/2	38.1	0.75	0.34
36-1 1/4	1/2	1 1/2	38.1	1 1/4	31.8	1 1/2	38.1	0.85	0.39
36-1 1/4	3/4	1 1/2	38.1	1 1/4	31.8	1 1/2	38.1	1.25	0.57
36-2	1	1 1/4	54.0	1 29/32	45.2	2 1/16	54.4	1.25	0.57
36-2	1 1/4	2 1/8	73.0	2 9/32	54.8	2 3/16	55.6	2.20	1.00
36-2	1 1/2	3 1/8	79.4	2 1/2	63.5	2 5/16	58.8	3.90	1.77
36-3	2	4 3/16	106.4	3 1/4	82.6	2 3/4	69.9	6.15	2.80

Lateral Outlets

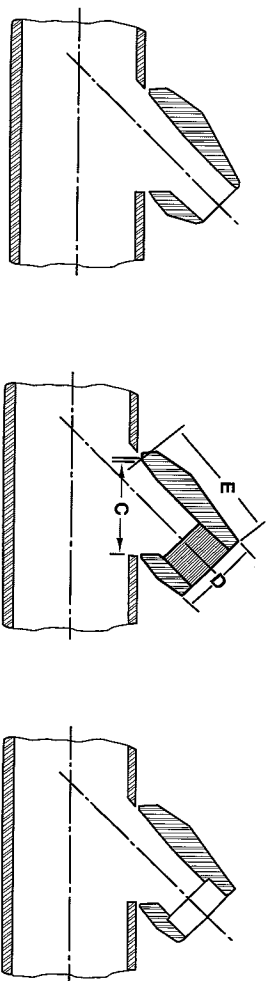

Dimensions for all three styles are the same except for the "D" dimension on the butt welding outlet which matches the proper schedule on the branch pipe.

3000 LBS THREADED AND SOCKETWELD Standard and Extra Strong Butt-weld

Nominal Elbow Size Inches	Outlet Size Inches	DIMENSIONS						Approx. Wt. lbs.	Kg.
		C	D	E	in	mm	mm		
12 1/2-3	1/4	1 1/2	38.5	1 1/4	31.8	1 1/2	39.7	0.50	0.23
12 1/2-3	3/8	1 1/2	38.5	1 1/4	31.8	1 1/2	39.7	0.50	0.23
12 1/2-3	1/2	1 1/2	38.5	1 1/4	31.8	1 1/2	39.7	0.65	0.30
12 1/2-3	3/4	1 1/2	38.5	1 1/4	31.8	1 1/2	39.7	0.75	0.34
12 1/2-6	1	1 1/4	54.0	1 29/32	45.2	2 1/16	57.2	1.15	0.52
12 1/2-6	1 1/4	2 1/8	67.5	2 9/32	54.6	2 3/16	61.9	1.90	0.86
12 1/2-6	1 1/2	3	76.2	2 1/2	63.5	2 5/16	66.7	2.65	1.20
12 1/2-6	2	4 1/8	104.8	3 1/4	82.6	3 3/16	81.0	5.25	2.39

6000 LBS THREADED AND SOCKETWELD Schedule 160 and Double Extra Strong Butt-weld

Nominal Elbow Size Inches	Outlet Size Inches	DIMENSIONS						Approx. Wt. lbs.	Kg.
		C	D	E	in	mm	mm		
12 1/2-3	1/4	1 1/2	38.5	1 1/4	31.8	1 1/2	39.7	0.50	0.23
12 1/2-3	3/8	1 1/2	38.5	1 1/4	31.8	1 1/2	39.7	0.50	0.23
12 1/2-3	1/2	1 1/2	38.5	1 1/4	31.8	1 1/2	39.7	0.65	0.30
12 1/2-3	3/4	1 1/2	38.5	1 1/4	31.8	1 1/2	39.7	0.75	0.34
12 1/2-6	1	1 1/4	54.0	1 29/32	45.2	2 1/16	57.2	1.15	0.52
12 1/2-6	1 1/4	2 1/8	67.5	2 9/32	54.6	2 3/16	61.9	1.90	0.86
12 1/2-6	1 1/2	3	76.2	2 1/2	63.5	2 5/16	66.7	2.65	1.20
12 1/2-6	2	4 1/8	104.8	3 1/4	82.6	3 3/16	81.0	5.25	2.39



Flanged Branch Outlets

There are many types of fittings in this group; they cover an extensive range and compliment the non-flanged range of Outlet fittings manufactured by SPROMAK LTD.

Flanged Branch Outlets encompass the following specific types:

FLANGED BUTTWELD OUTLET ——— FLANGED BUTTWELD OUTLET LIGHTWEIGHT
FLANGED NIPPLE OUTLET ——— FLANGED NIPPLE OUTLET LIGHTWEIGHT
FLANGED LATERAL OUTLET ——— FLANGED LATERAL OUTLET LIGHTWEIGHT
FLANGED ELBOW OUTLET ——— FLANGED ELBOW OUTLET LIGHTWEIGHT
FLANGED INSERT OUTLET

Each Flanged Branch Outlet is designed to fully compensate the hole cut into the header pipe.

The tabulated data is applicable for header and branch pipes of the same wall thickness or schedule i.e. STD/STD or XS/XS etc. Flanged Branch Outlets are also supplied for various other wall thickness and outlet sizes not shown in the published data. These fittings can be supplied to fit any header pipe, pressure vessel, dished end or flat end. Dimensional data is available on request.

Custom made items are readily produced to suit specific piping or pressure vessel layout requirements.

Flanged Branch Outlets are supplied in most types of forged metals, from carbon and alloy steels, through stainless and super duplex, to aluminium and Cu. Ni. alloys.

The flanged part of the fitting complies with ANSI B16.9. The compensation and base part of the fitting complies with our equivalent Butt weld, Nipple, Lateral, Elbow or Insert Outlet which would be used for the same header and branch pipe sizes and wall thicknesses.

These fittings have undergone extensive full size Internal Pressure Proof Testing in accordance with ANSI B16.9. They can be supplied to comply with any piping or pressure vessel code.

Flanged Branch Outlets are available with branch ends suitable for use with various proprietary flanged end type connectors.

ORDERING INFORMATION

Data we require to service your enquiry/order.

- 1) HEADER SIZE: O.D. or I.D. or N.B.
- 2) BRANCH SIZE: O.D. or I.D. or N.B.
- 3) HEADER WALL THICKNESS: Schedule, or actual thickness.
- 4) BRANCH WALL THICKNESS: Schedule, or actual thickness.
- 5) TYPE OF FITTING: Flanged Butt weld Outlet, etc.
- 6) FLANGE RATING: 150lb, etc.
- 7) FLANGE FACING: RTJ. etc.
- 8) MATERIAL: ASTM A182 F316L, etc.
- 9) ANY SPECIAL REQUIREMENTS: Special 'A' size, etc.

REINFORCEMENT CALCULATIONS

If reinforcement calculations are required, the following data should be supplied with the enquiry.

- 1) DESIGN CODE: (e.g. ANSIE B31.3) etc.
- 2) DESIGN TEMPERATURE: (e.g. -46 to +100 deg C) etc.
- 3) DESIGN PRESSURE: (e.g. 350 barg) etc.
- 4) DESIGN STRESS, HEADER & BRANCH PIPES: (e.g. 450 N/mm) etc.
- 5) MATERIAL, HEADER & BRANCH PIPES: e.g. (ASTM A 335 P22) etc.
- 6) CORROSION ALLOWANCE, HEADER & BRANCH PIPES: (e.g. 1.5mm) etc.
- 7) MILL TOLERANCE, HEADER & BRANCH PIPES: (e.g. 12.5%) etc.



Flanged Butt weld Outlets

• 150 lbs

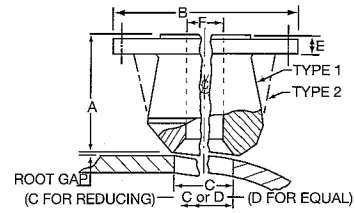

DIMENSIONS FOR HEADER AND BRANCH WALL STD / STD

OUTLET SIZE	EQUAL AND REDUCING __STD__ / __STD__ (unless shown thus*)						Weight	Type
	B	E	A	C	D	F		
1/2	88.90	11.20	65.00	24.00	15.80	15.80	0.67	1
3/4	98.60	12.70	75.00	30.00	21.00	20.93	1.05	1
1	107.95	14.30	85.00	36.50	26.60	26.60	1.65	1
1 1/4	117.50	15.90	90.00	44.50	35.00	35.00	2.24	1
1 1/2	127.00	17.50	95.00	51.00	40.90	40.90	2.83	1
2	152.40	19.05	105.00	65.00	52.50	52.50	4.31	1
2 1/2	177.80	22.25	112.00	76.15	62.80	62.80		1
3	190.50	23.82	115.00	93.50	78.00	78.00		1
3 1/2	215.90	23.82	120.00	112.60	90.20	90.20		1
4	228.60	23.82	130.00	120.50	102.20	102.20		1
5	254.00	23.82	146.00	141.30	128.20	128.20		1
6	279.40	25.40	150.00	170.00	154.00	154.00		1
8	342.90	28.60	175.00	220.50	202.70	202.70		1
10	406.40	30.20	180.00	274.00	254.50	254.50		1
12	482.60	31.75	200.00	324.00	304.80	304.80		1
14	533.40	34.93	220.00	356.00	336.50	336.50		1
16	596.90	36.52	225.00	406.00	387.35	387.35		1
18 R*	635.00	39.70	240.00	459.00	-	483.15		1
18 E*	635.00	39.70	245.00	473.00	483.15	483.15		1
20 R*	698.50	42.87	250.00	508.00	-	489.00		1
20 E*	698.50	42.87	265.00	508.00	489.00	489.00		1
24	812.63	47.63	300.00	609.00	590.50	590.50		1

R* indicates reducing size only. E* indicates equal size only. The unit of weight is kg. Weights given are for carbon steel. Raised Face flanges shown. Other facings are available

Flanged Butt weld Outlets • 300 lbs

DIMENSIONS FOR HEADER AND BRANCH WALL STD / STD

OUTLET SIZE	EQUAL AND REDUCING __STD__ / __STD__ (unless shown thus*)						Weight	Type
	B	E	A	C	D	F		
1/2	95.25	14.30	70.00	24.00	15.80	15.80	0.99	2
3/4	117.50	15.90	80.00	30.00	21.00	20.93	1.72	2
1	123.80	17.50	90.00	36.50	26.60	26.60	2.29	1
1 1/4	133.35	19.00	95.00	44.50	35.00	35.00	3.01	1
1 1/2	155.60	20.60	100.00	51.00	40.90	40.90	4.12	1
2	165.10	22.20	110.00	65.00	52.50	52.50	5.36	1
2 1/2	190.50	25.40	120.00	76.15	62.80	62.80		1
3	209.55	28.60	125.00	93.50	78.00	78.00		1
3 1/2	228.60	30.20	130.00	112.60	90.20	90.20		1
4	254.00	31.75	140.00	120.50	102.20	102.20		1
5	279.40	34.93	155.00	141.30	128.20	128.20		1
6	317.50	36.52	160.00	170.00	154.00	154.00		1
8	381.00	41.28	180.00	220.50	202.70	202.70		1
10	444.50	47.63	195.00	274.00	254.50	254.50		1
12	520.70	50.80	215.00	324.00	304.80	304.80		1
14	584.20	53.98	230.00	356.00	336.50	336.50		2
16	647.70	57.15	240.00	406.00	387.35	387.35		2
18 R*	711.20	60.33	255.00	459.00	-	483.15		2
18 E*	711.20	60.33	260.00	473.00	483.15	483.15		2
20 R*	774.70	63.50	265.00	508.00	-	489.00		2
20 E*	774.70	63.50	280.00	508.00	489.00	489.00		2
24	914.40	69.85	310.00	609.00	590.50	590.50		1

R* indicates reducing size only. E* indicates equal size only. The unit of weight is kg. Weights given are for carbon steel. Raised Face flanges shown. Other facings are available



Flanged Butt Weld Outlets

• 600 lbs

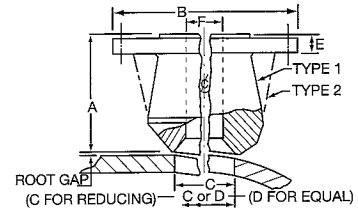

DIMENSIONS FOR HEADER AND BRANCH WALL STD / STD

OUTLET SIZE	EQUAL AND REDUCING STD / STD (unless shown thus*)						Weight	Type
	B	E	A	C	D	F		
1/2	95.25	20.65	80.00	24.00	15.80	15.80	1.13	2
3/4	117.50	22.25	85.00	30.00	21.00	20.93	1.86	2
1	123.80	23.85	95.00	36.50	26.60	26.60	2.46	1
1 1/4	133.35	26.95	105.00	44.50	35.00	35.00	3.43	1
1 1/2	155.60	28.55	110.00	51.00	40.90	40.90	4.68	1
2	165.10	31.75	120.00	65.00	52.50	52.50	6.18	1
2 1/2	190.50	34.95	125.00	76.15	62.80	62.80		1
3	209.55	38.10	135.00	93.50	78.00	78.00		1
3 1/2	228.60	42.28	140.00	112.60	90.20	90.20		1
4	273.05	44.45	160.00	120.50	102.20	102.20		1
5	330.20	50.80	180.00	141.30	128.20	128.20		2
6	355.60	53.98	185.00	170.00	154.00	154.00		2
8	419.10	61.95	210.00	220.50	202.70	202.70		2
10	508.00	69.85	240.00	274.00	254.50	254.50		2
12	558.80	73.03	250.00	324.00	304.80	304.80		2
14	603.20	76.20	260.00	356.00	336.50	336.50		2
16	685.80	82.55	280.00	406.00	387.35	387.35		2
18 R*	724.90	88.90	290.00	459.00	-	483.15		2
18 E*	724.90	88.90	295.00	473.00	483.15	483.15		2
20 R*	812.80	95.25	300.00	508.00	-	489.00		2
20 E*	812.80	95.25	315.00	508.00	489.00	489.00		2
24	939.80	107.95	355.00	609.00	590.50	590.50		1

R* indicates reducing size only. E* indicates equal size only. The unit of weight is kg. Weights given are for carbon steel. Raised Face flanges shown. Other facings are available

Flanged Butt Weld Outlets • 900 lbs

DIMENSIONS FOR HEADER AND BRANCH WALL STD / STD

OUTLET SIZE	EQUAL AND REDUCING STD / STD (unless shown thus*)						Weight	Type
	B	E	A	C	D	F		
1/2	120.65	28.55	85.00	24.00	15.80	15.80	2.11	2
3/4	130.20	31.75	100.00	30.00	21.00	20.93	2.97	1
1	149.20	34.95	105.00	36.50	26.60	26.60	4.33	1
1 1/4	158.80	34.95	110.00	44.50	35.00	35.00	5.23	1
1 1/2	177.80	38.05	125.00	51.00	40.90	40.90	7.19	1
2	215.90	44.45	145.00	65.00	52.50	52.50	13.42	2
2 1/2	244.50	47.65	155.00	76.15	62.80	62.80		2
3	241.30	44.45	155.00	93.50	78.00	78.00		2
4	292.10	50.80	170.00	120.50	102.20	102.20		2
5	349.25	57.15	190.00	141.30	128.20	128.20		2
6	381.00	61.98	210.00	170.00	154.00	154.00		2
8	469.90	69.85	240.00	220.50	202.70	202.70		2
10	546.10	76.20	270.00	274.00	254.50	254.50		2
12	609.60	85.60	295.00	324.00	304.80	304.80		2
14	641.35	92.20	310.00	356.00	336.50	336.50		2
16	704.85	95.25	315.00	406.00	387.35	387.35		2
18 R*	787.40	107.95	330.00	459.00	-	483.15		2
18 E*	787.40	107.95	340.00	473.00	483.15	483.15		2
20 R*	857.25	114.30	355.00	508.00	-	489.00		2
20 E*	857.25	114.30	370.00	508.00	489.00	489.00		2
24	1041.40	146.05	445.00	609.00	590.50	590.50		2

R* indicates reducing size only. E* indicates equal size only. The unit of weight is kg. Weights given are for carbon steel. Raised Face flanges shown. Other facings are available

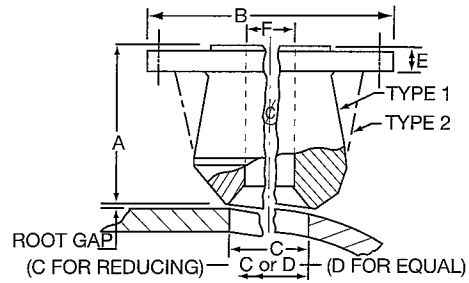

Flanged Butt Weld Outlets • 1500 lbs

DIMENSIONS FOR HEADER AND BRANCH WALL STD / STD

OUTLET SIZE	EQUAL AND REDUCING ___STD___/___STD___(unless shown thus*)						Weight	Type
	B	E	A	C	D	F		
1/2	120.65	28.55	85.00	24.00	15.80	15.80	2.11	2
3/4	130.20	31.75	100.00	30.00	21.00	20.93	2.97	1
1	149.20	34.95	105.00	36.50	26.60	26.60	4.33	1
1 1/4	158.80	34.95	110.00	44.50	35.00	35.00	5.23	1
1 1/2	177.80	38.05	125.00	51.00	40.90	40.90	7.19	1
2	215.90	44.45	145.00	65.00	52.50	52.50	13.42	2
2 1/2	244.50	47.65	155.00	76.15	62.80	62.80		2
3	266.70	53.98	170.00	93.50	78.00	78.00		2
4	311.10	60.35	180.00	120.50	102.20	102.20		2
5	374.60	79.38	220.00	141.30	128.20	128.20		2
6	393.70	88.90	240.00	170.00	154.00	154.00		2
8	482.60	98.45	290.00	220.50	202.70	202.70		2
10	584.20	114.30	340.00	274.00	254.50	254.50		2
12	673.10	130.18	375.00	324.00	304.80	304.80		2
14	749.30	139.70	395.00	356.00	336.50	336.50		2
16	825.50	152.40	410.00	406.00	387.35	387.35		2
18 R*	914.40	168.28	430.00	459.00	-	483.15		2
18 E*	914.40	168.28	435.00	473.00	483.15	483.15		2
20 R*	984.20	184.15	465.00	508.00	-	489.00		2
20 E*	984.20	184.15	480.00	508.00	489.00	489.00		2
24	1168.40	209.55	555.00	609.00	590.50	590.50		2

R* indicates reducing size only. E* indicates equal size only. The unit of weight is kg. Weights given are for carbon steel. Raised Face flanges shown. Other facings are available

Flanged Butt Weld Outlets • 2500 lbs

DIMENSIONS FOR HEADER AND BRANCH WALL STD / STD

OUTLET SIZE	EQUAL AND REDUCING ___STD___/___STD___(unless shown thus*)						Weight	Type
	B	E	A	C	D	F		
1/2	133.35	36.51	100.00	24.00	15.80	15.80	3.82	2
3/4	139.70	38.10	110.00	30.00	21.00	20.93	4.64	2
1	158.75	41.28	125.00	36.50	26.60	26.60	6.38	2
1 1/4	184.15	44.45	135.00	44.50	35.00	35.00	9.32	2
1 1/2	203.20	50.80	150.00	51.00	40.90	40.90	12.42	2
2	234.95	57.15	170.00	65.00	52.50	52.50	18.40	2
2 1/2	266.70	63.50	190.00	76.15	62.80	62.80		2
3	304.80	73.03	220.00	93.50	78.00	78.00		2
4	355.60	82.55	250.00	120.50	102.20	102.20		2
5	419.10	98.43	290.00	141.30	128.20	128.20		2
6	482.60	114.30	340.00	170.00	154.00	154.00		2
8	552.45	133.35	395.00	220.50	202.70	202.70		2
10	673.10	171.45	505.00	274.00	254.50	254.50		2
12	762.00	190.50	555.00	324.00	304.80	304.80		2

R* indicates reducing size only. E* indicates equal size only. The unit of weight is kg. Weights given are for carbon steel. Raised Face flanges shown. Other facings are available

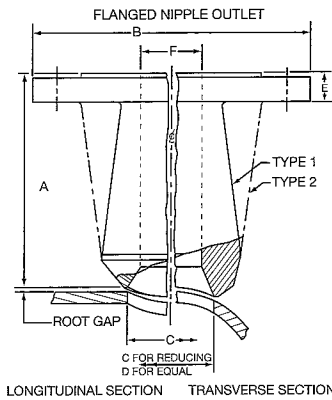

Flanged Nipple Outlets • 150 lbs

OUTLET SIZE	EQUAL AND REDUCING _STD_ / _STD_						Weight	Type
	B	E	A	C	D	F		
1/2	88.90	11.20	150.00	24.00	15.80	15.80	1.10	1
3/4	98.60	12.70	150.00	30.00	21.00	20.93	1.66	1
1	107.95	14.30	150.00	36.50	26.60	26.60	2.43	1
1 1/4	117.50	15.90	150.00	44.50	35.00	35.00	3.25	1
1 1/2	127.00	17.50	150.00	51.00	40.90	40.90	3.88	1
2	152.40	19.05	150.00	65.00	52.50	52.50	5.48	1

Flanged Nipple Outlets • 300 lbs

OUTLET SIZE	EQUAL AND REDUCING _STD_ / _STD_						Weight	Type
	B	E	A	C	D	F		
1/2	95.25	14.30	150.00	24.00	15.80	15.80	1.53	2
3/4	117.50	15.90	150.00	30.00	21.00	20.93	2.43	2
1	123.80	17.50	150.00	36.50	26.60	26.60	3.16	1
1 1/4	133.35	19.00	150.00	44.50	35.00	35.00	4.00	1
1 1/2	155.60	20.60	150.00	51.00	40.90	40.90	5.18	1
2	165.10	22.20	150.00	65.00	52.50	52.50	6.52	1

Flanged Nipple Outlets • 600 lbs

OUTLET SIZE	EQUAL AND REDUCING _STD_ / _STD_						Weight	Type
	B	E	A	C	D	F		
1/2	95.25	20.65	150.00	24.00	15.80	15.80	1.59	2
3/4	117.50	22.25	150.00	30.00	21.00	20.93	2.52	2
1	123.80	23.85	150.00	36.50	26.60	26.60	3.30	1
1 1/4	133.35	26.95	150.00	44.50	35.00	35.00	4.23	1
1 1/2	155.60	28.55	150.00	51.00	40.90	40.90	5.53	1
2	165.10	31.75	150.00	65.00	52.50	52.50	7.05	1

Flanged Nipple Outlets • 900-1500 lbs

OUTLET SIZE	EQUAL AND REDUCING _STD_ / _STD_						Weight	Type
	B	E	A	C	D	F		
1/2	120.65	28.55	150.00	24.00	15.80	15.80	2.54	2
3/4	130.20	31.75	150.00	30.00	21.00	20.93	3.50	1
1	149.20	34.95	150.00	36.50	26.60	26.60	4.92	1
1 1/4	158.80	34.95	150.00	44.50	35.00	35.00	5.94	1
1 1/2	177.80	38.05	150.00	51.00	40.90	40.90	7.74	1
2	215.90	44.45	150.00	65.00	52.50	52.50	13.62	2

The unit of weight is kg. Weights given are for carbon steel. Raised Face flanges shown. Other facings are available

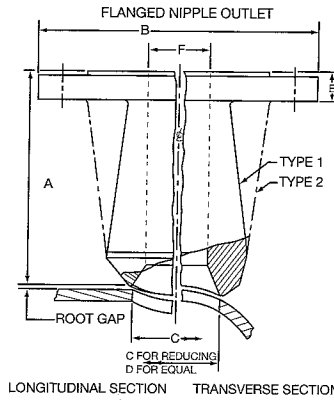

Flanged Nipple Outlets • 2500 lbs

OUTLET SIZE	EQUAL AND REDUCING STD / STD						Weight	Type
	B	E	A	C	D	F		
1/2	133.35	36.55	150.00	24.00	15.80	15.80	3.82	2
3/4	139.70	38.05	150.00	30.00	21.00	20.93	4.64	2
1	158.75	41.25	150.00	36.50	26.60	26.60	6.38	2
1 1/4	184.15	44.45	150.00	44.50	35.00	35.00	9.32	2
1 1/2	203.20	50.75	150.00	51.00	40.90	40.90	12.42	2
2	234.95	57.15	165.00	65.00	52.50	52.50	18.40	2

Flanged Nipple Outlets • 150 lbs

OUTLET SIZE	EQUAL AND REDUCING XS / XS						Weight	Type
	B	E	A	C	D	F		
1/2	88.90	11.20	150.00	24.00	13.90	13.90	1.14	1
3/4	98.60	12.70	150.00	30.00	18.90	18.90	1.70	1
1	107.95	14.30	150.00	36.50	24.30	24.30	2.54	1
1 1/4	117.50	15.90	150.00	44.50	32.50	32.50	3.41	1
1 1/2	127.00	17.50	150.00	51.00	38.10	38.10	4.09	1
2	152.40	19.05	150.00	65.00	49.30	49.30	5.79	1

Flanged Nipple Outlets • 300 lbs

OUTLET SIZE	EQUAL AND REDUCING XS / XS						Weight	Type
	B	E	A	C	D	F		
1/2	95.25	14.30	150.00	24.00	13.90	13.90	1.58	2
3/4	117.50	15.90	150.00	30.00	18.90	18.90	2.50	2
1	123.80	17.50	150.00	36.50	24.30	24.30	3.27	1
1 1/4	133.35	19.00	150.00	44.50	32.50	32.50	4.16	1
1 1/2	155.60	20.60	150.00	51.00	38.10	38.10	5.39	1
2	165.10	22.20	150.00	65.00	49.30	49.30	6.83	1

Flanged Nipple Outlets • 600 lbs

OUTLET SIZE	EQUAL AND REDUCING XS / XS						Weight	Type
	B	E	A	C	D	F		
1/2	95.25	20.65	150.00	24.00	13.90	13.90	1.64	2
3/4	117.50	22.25	150.00	30.00	18.90	18.90	2.60	2
1	123.80	23.85	150.00	36.50	24.30	24.30	3.36	1
1 1/4	133.35	26.95	150.00	44.50	32.50	32.50	4.40	1
1 1/2	155.60	28.55	150.00	51.00	38.10	38.10	5.73	1
2	165.10	31.75	150.00	65.00	49.30	49.30	7.36	1

The unit of weight is kg. Weights given are for carbon steel. Raised Face flanges shown. Other facings are available

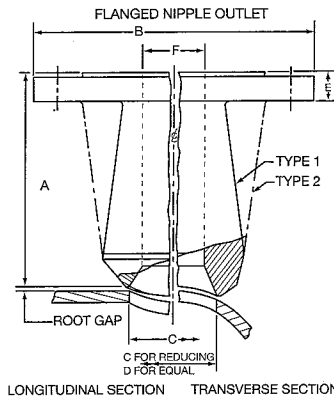

Flanged Nipple Outlets • 900-1500 lbs

OUTLET SIZE	EQUAL AND REDUCING __XS_ / __XS_						Weight	Type
	B	E	A	C	D	F		
1/2	120.65	28.55	150.00	24.00	13.90	13.90	2.59	2
3/4	130.20	31.75	150.00	30.00	18.90	18.90	3.58	1
1	149.20	34.95	150.00	36.50	24.30	24.30	5.03	1
1 1/4	158.80	34.95	150.00	44.50	32.50	32.50	6.10	1
1 1/2	177.80	38.05	150.00	51.00	38.10	38.10	7.94	1
2	215.90	44.45	150.00	65.00	49.30	49.30	13.93	2

Flanged Nipple Outlets • 2500 lbs

OUTLET SIZE	EQUAL AND REDUCING __XS_ / __XS_						Weight	Type
	B	E	A	C	D	F		
1/2	133.35	36.55	150.00	24.00	13.90	13.90	3.87	2
3/4	139.70	38.05	150.00	30.00	18.90	18.90	4.71	2
1	158.75	41.25	150.00	36.50	24.30	24.30	6.49	2
1 1/4	184.15	44.45	150.00	44.50	32.50	32.50	9.48	2
1 1/2	203.20	50.75	150.00	51.00	38.10	38.10	12.62	2
2	234.95	57.15	165.00	65.00	49.30	49.30	18.74	2

Flanged Nipple Outlets • 150 lbs

OUTLET SIZE	EQUAL AND REDUCING __S_160_ / __S_160_						Weight	Type
	B	E	A	C	D	F		
1/2	88.90	11.20	150.00	14.30	14.30	11.84	1.23	1
3/4	98.60	12.70	150.00	19.00	19.00	15.60	1.83	1
1	107.95	14.30	150.00	25.50	25.50	20.70	2.55	1
1 1/4	117.50	15.90	150.00	33.40	33.40	29.46	3.42	1
1 1/2	127.00	17.50	150.00	38.00	38.00	33.98	4.19	1
2	152.40	19.05	150.00	42.90	42.90	42.90	5.81	1

Flanged Nipple Outlets • 300 lbs

OUTLET SIZE	EQUAL AND REDUCING __S_160_ / __S_160_						Weight	Type
	B	E	A	C	D	F		
1/2	95.25	14.30	150.00	14.30	14.30	11.84	1.62	2
3/4	117.50	15.90	150.00	19.00	19.00	15.60	2.64	2
1	123.80	17.50	150.00	25.50	25.50	20.70	3.23	2
1 1/4	133.35	19.00	150.00	33.40	33.40	29.46	4.17	2
1 1/2	155.60	20.60	150.00	38.00	38.00	33.98	5.52	1
2	165.10	22.20	150.00	42.90	42.90	42.90	6.84	2

The unit of weight is kg. Weights given are for carbon steel. Raised Face flanges shown. Other facings are available

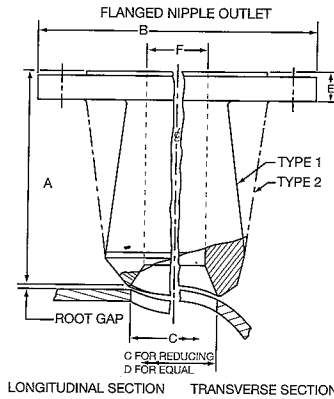

Flanged Nipple Outlets • 600 lbs

OUTLET SIZE	EQUAL AND REDUCING __S__160__/_S__160							Weight	Type
	B	E	A	C	D	F			
1/2	95.25	20.65	150.00	14.30	14.30	11.84	1.69	2	
3/4	117.50	22.25	150.00	19.00	19.00	15.60	2.73	2	
1	123.80	23.85	150.00	25.50	25.50	20.70	3.38	2	
1 1/4	133.35	26.95	150.00	33.40	33.40	29.46	4.41	2	
1 1/2	155.60	28.55	150.00	38.00	38.00	33.98	5.84	1	
2	165.10	31.75	150.00	42.90	42.90	42.90	7.41	2	

Flanged Nipple Outlets • 900-1500 lbs

OUTLET SIZE	EQUAL AND REDUCING __S__160__/_S__160							Weight	Type
	B	E	A	C	D	F			
1/2	120.65	28.55	150.00	14.30	14.30	11.84	2.64	2	
3/4	130.20	31.75	150.00	19.00	19.00	15.60	3.68	1	
1	149.20	34.95	150.00	25.50	25.50	20.70	5.06	2	
1 1/4	158.80	34.95	150.00	33.40	33.40	29.46	6.13	2	
1 1/2	177.80	38.05	150.00	38.00	38.00	33.98	8.16	1	
2	215.90	44.45	150.00	42.90	42.90	42.90	13.98	2	

Flanged Nipple Outlets • 2500 lbs

OUTLET SIZE	EQUAL AND REDUCING __S__160__/_S__160							Weight	Type
	B	E	A	C	D	F			
1/2	133.35	36.55	150.00	14.30	14.30	11.84	3.92	2	
3/4	139.70	38.05	150.00	19.00	19.00	15.60	4.84	2	
1	158.75	41.25	150.00	25.50	25.50	20.70	6.52	2	
1 1/4	184.15	44.45	150.00	33.40	33.40	29.46	9.51	2	
1 1/2	203.20	50.75	150.00	38.00	38.00	33.98	12.75	2	
2	234.95	57.15	165.00	42.90	42.90	42.90	18.86	2	

Flanged Nipple Outlets • 150 lbs

OUTLET SIZE	EQUAL AND REDUCING __XXS__/_XXS__							Weight	Type
	B	E	A	C	D	F			
1/2	88.90	11.20	150.00	14.30	14.30	6.40	1.28	1	
3/4	98.60	12.70	150.00	19.00	19.00	11.03	1.91	1	
1	107.95	14.30	150.00	25.50	25.50	15.21	2.74	1	
1 1/4	117.50	15.90	150.00	33.40	33.40	22.76	3.75	1	
1 1/2	127.00	17.50	150.00	38.00	38.00	27.94	4.53	1	
2	152.40	19.05	150.00	42.90	42.90	38.18	6.16	1	

The unit of weight is kg. Weights given are for carbon steel. Raised Face flanges shown. Other facings are available

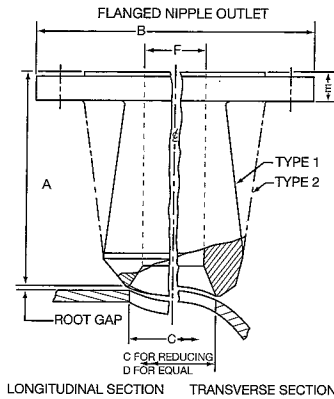

Flanged Nipple Outlets • 300 lbs

OUTLET SIZE	EQUAL AND REDUCING __XXS / __XXS__						Weight	Type
	B	E	A	C	D	F		
1/2	95.25	14.30	150.00	14.30	14.30	6.40	1.72	2
3/4	117.50	15.90	150.00	19.00	19.00	11.03	2.71	2
1	123.80	17.50	150.00	25.50	25.50	15.21	3.42	2
1 1/4	133.35	19.00	150.00	33.40	33.40	22.76	4.49	2
1 1/2	155.60	20.60	150.00	38.00	38.00	27.94	5.86	1
2	165.10	22.20	150.00	42.90	42.90	38.18	7.20	2

Flanged Nipple Outlets • 600 lbs

OUTLET SIZE	EQUAL AND REDUCING __XXS / __XXS__						Weight	Type
	B	E	A	C	D	F		
1/2	95.25	20.65	150.00	14.30	14.30	6.40	1.72	2
3/4	117.50	22.25	150.00	19.00	19.00	11.03	2.80	2
1	123.80	23.85	150.00	25.50	25.50	15.21	3.52	2
1 1/4	133.35	26.95	150.00	33.40	33.40	22.76	4.74	2
1 1/2	155.60	28.55	150.00	38.00	38.00	27.94	6.30	1
2	165.10	31.75	150.00	42.90	42.90	38.18	7.77	2

Flanged Nipple Outlets • 900-1500 lbs

OUTLET SIZE	EQUAL AND REDUCING __XXS / __XXS__						Weight	Type
	B	E	A	C	D	F		
1/2	120.65	28.55	150.00	14.30	14.30	6.40	2.73	2
3/4	130.20	31.75	150.00	19.00	19.00	11.03	3.80	1
1	149.20	34.95	150.00	25.50	25.50	15.21	5.25	2
1 1/4	158.80	34.95	150.00	33.40	33.40	22.76	6.45	2
1 1/2	177.80	38.05	150.00	38.00	38.00	27.94	8.51	1
2	215.90	44.45	150.00	42.90	42.90	38.18	14.34	2

Flanged Nipple Outlets • 2500 lbs

OUTLET SIZE	EQUAL AND REDUCING __XXS / __XXS__						Weight	Type
	B	E	A	C	D	F		
1/2	133.35	36.55	150.00	14.30	14.30	6.40	4.01	2
3/4	139.70	38.05	150.00	19.00	19.00	11.03	5.00	2
1	158.75	41.25	150.00	25.50	25.50	15.21	6.71	2
1 1/4	184.15	44.45	150.00	33.40	33.40	22.76	9.84	2
1 1/2	203.20	50.75	150.00	38.00	38.00	27.94	13.10	2
2	234.95	57.15	165.00	42.90	42.90	38.18	19.25	2

The unit of weight is kg. Weights given are for carbon steel. Raised Face flanges shown. Other facings are available



Material Specifications (FORGED PRODUCTS)

Forged fittings and other products can be supplied to any relevant material specification such as: ASTM, BS, DIN standards etc.

Spromak Ltd®, are pleased to be able to supply fittings in any material grade used today by industry.

Some of the more common material specifications are listed below.

CARBON STEELS

ASTM: A105N, A350-LF2, A350-LF3, A694-F46, A694-F52, A694-F60, A694-F65.

STAINLESS STEELS

ASTM: A182-F304*, A812-F310*, A182-F316*, A182-F321*, A182-F347*, A182-F348*.

ALLOY STEELS

ASTM: A182-F1*, A182-F5*, A182-F6*, A182-F9*, A182-F11*, A182-F12*, A182-F21*, A182-F22*.

SPECIAL ALLOYS

ASTM: A182-F51 Duplex and Super Duplex.

ASTM: A182-F44 (6 Mo).

CUPRO NICKEL 90/10, and 70/30.

ALUMINIUM ALLOYS.

ALLOY 400, 625, 800 and 825.

NICKEL 200

* These materials are also available in various sub-grades as listed in the ASTM Standards

Examples of our previous projects

Project	Client	Country
Scott Field	Amerada Hess	UK
Shell Nelson	Shell UK Exploration	UK
Piper Bravo	Elf Caledonian	UK
ADCO	Abu Dhabi Oil Co	Abu Dhabi
British Gas N.Morcambe	British Gas	UK
British Gas Rough Enhancement	British Gas	UK
Judy-Joanne	Phillips Petroleum	UK
Troll Onshore	Statoil	Norway
Goodwyn Platform A	Woodside Petroleum	Australia
Saga Snorre	Saga Petroleum	Norway

BUTTWELD OUTLET BORES and ASA SCHEDULES (dimensions in inches)

Nominal pipe size	1/2	3/4	1	1 1/4	1 1/2	2	2 1/2	3	3 1/2	4	5	6	8	10	12	14	16	18	20	22	24	26
Outside diameter	0.840	1.050	1.315	1.660	1.900	2.375	2.875	3.500	4.000	4.500	5.563	6.625	8.625	10.750	12.750	14.000	16.000	18.000	20.000	22.000	24.000	26.000
Schedule 5S	0.710	0.920	1.185	1.530	1.770	2.245	2.709	3.334	3.834	4.334	5.345	6.407	8.407	10.482	12.438	13.688	15.670	17.670	19.624	21.624	23.564	-
Schedule 10S	0.674	0.884	1.097	1.442	1.682	2.157	2.635	3.260	3.760	4.260	5.295	6.357	8.329	10.420	12.390	13.500	15.500	17.500	19.500	21.500	23.500	-
Schedule 10	0.674	0.884	1.097	1.442	1.682	2.157	2.635	3.260	3.760	4.260	5.295	6.357	8.329	10.420	12.390	13.500	15.500	17.500	19.500	21.500	23.500	-
Schedule 20	-	-	-	-	-	-	-	-	-	-	-	-	8.125	10.250	12.250	13.376	15.376	17.376	19.250	21.250	23.250	-
Schedule 30	-	-	-	-	-	-	-	-	-	-	-	-	8.071	10.137	12.090	13.250	15.250	17.124	19.000	21.000	22.876	-
Schedule 40S	0.622	0.824	1.049	1.380	1.610	2.067	2.469	3.068	3.548	4.026	5.047	6.065	7.981	10.020	12.000	13.250	15.250	17.250	19.250	21.250	23.250	25.250
Standard Wall	0.622	0.824	1.049	1.380	1.610	2.067	2.469	3.068	3.548	4.026	5.047	6.065	7.981	10.020	12.000	13.250	15.250	17.250	19.250	21.250	23.250	25.250
Schedule 40	0.622	0.824	1.049	1.380	1.610	2.067	2.469	3.068	3.548	4.026	5.047	6.065	7.981	10.020	11.938	13.124	15.000	16.876	18.814	20.750	22.626	-
Schedule 60	-	-	-	-	-	-	-	-	-	-	-	-	7.813	9.750	11.626	12.814	14.688	16.500	18.376	20.250	22.064	-
Schedule 80S	0.546	0.742	0.957	1.278	1.500	1.939	2.323	2.900	3.364	3.826	4.813	5.761	7.625	9.564	11.750	13.250	15.250	17.250	19.250	21.250	23.250	25.250
Extra Strong	0.546	0.742	0.957	1.278	1.500	1.939	2.323	2.900	3.364	3.826	4.813	5.761	7.625	9.564	11.750	13.000	15.000	17.000	19.000	21.000	23.000	25.000
Schedule 80	0.546	0.742	0.957	1.278	1.500	1.939	2.323	2.900	3.364	3.826	4.813	5.761	7.625	9.564	11.376	12.500	14.314	16.126	17.938	19.750	21.564	-
Schedule 100	-	-	-	-	-	-	-	-	-	-	-	-	7.439	9.314	11.064	12.126	13.938	15.688	17.438	19.250	20.938	-
Schedule 120	-	-	-	-	-	-	-	-	-	3.624	4.563	5.501	7.189	9.064	10.750	11.814	13.564	15.250	17.000	18.750	20.376	-
Schedule 140	-	-	-	-	-	-	-	-	-	-	-	-	7.001	8.750	10.500	11.500	13.124	14.876	16.500	18.250	19.876	-
Schedule 160	0.466	0.614	0.815	1.160	1.338	1.689	2.125	2.624	-	3.438	4.313	5.189	6.813	8.500	10.126	11.188	12.814	14.438	16.064	17.750	19.314	-
Double Extra Strong	0.252	0.434	0.599	0.896	1.100	1.503	1.771	2.300	2.728	3.152	4.063	4.897	6.875	8.750	10.750	-	-	-	-	-	-	-

DIMENSIONS OF SELECTED SIZES OF SEAMLESS L PIPE TO BS.1600 and ANSI B.36.10 and B3619 Wall Thickness (All dimensions in inches)

Nominal pipe size	1/2	3/4	1	1 1/4	1 1/2	2	2 1/2	3	3 1/2	4	5	6	8	10	12	14	16	18	20	22	24	26	30	36
Outside diameter	0.840	1.050	1.315	1.660	1.900	2.375	2.875	3.500	4.000	4.500	5.563	6.625	8.625	10.750	12.750	14.000	16.000	18.000	20.000	22.000	24.000	26.000	30.000	36.000
Schedule 5S	0.065	0.065	0.065	0.065	0.065	0.065	0.083	0.083	0.083	0.083	0.109	0.109	0.109	0.134	0.156	0.156	0.165	0.165	0.188	0.188	0.218	-	0.250	-
Schedule 10S	0.083	0.083	0.109	0.109	0.109	0.109	0.120	0.120	0.120	0.134	0.134	0.148	0.165	0.180	0.188	0.188	0.188	0.218	0.218	0.250	-	0.312	-	-
Schedule 10	0.083	0.083	0.109	0.109	0.109	0.109	0.120	0.120	0.120	0.134	0.134	0.148	0.165	0.180	0.250	0.250	0.250	0.250	0.250	0.250	0.312	0.312	0.312	0.312
Schedule 20	-	-	-	-	-	-	-	-	-	-	-	-	0.250	0.250	0.312	0.312	0.312	0.375	0.375	0.375	0.500	0.500	0.500	0.500
Schedule 30	-	-	-	-	-	-	-	-	-	-	-	-	0.277	0.307	0.330	0.375	0.375	0.438	0.500	0.500	0.562	-	0.625	0.625
Schedule 40S	0.109	0.113	0.133	0.140	0.145	0.154	0.203	0.216	0.226	0.237	0.258	0.280	0.322	0.365	0.375	-	-	-	-	-	-	-	-	-
Standard Wall	0.109	0.113	0.133	0.140	0.145	0.154	0.203	0.216	0.226	0.237	0.258	0.280	0.322	0.365	0.375	0.375	0.375	0.375	0.375	0.375	0.375	0.375	0.375	0.375
Schedule 40	0.109	0.113	0.133	0.140	0.145	0.154	0.203	0.216	0.226	0.237	0.258	0.280	0.322	0.365	0.406	0.438	0.500	0.562	0.593	0.625	0.687	-	-	0.750
Schedule 60	-	-	-	-	-	-	-	-	-	-	-	-	0.406	0.500	0.562	0.593	0.656	0.750	0.812	0.875	0.968	-	-	-
Schedule 80S	0.147	0.154	0.179	0.191	0.200	0.218	0.276	0.300	0.318	0.337	0.375	0.432	0.500	0.500	0.500	-	-	-	-	-	-	-	-	-
Extra Strong	0.147	0.154	0.179	0.191	0.200	0.218	0.276	0.300	0.318	0.337	0.375	0.432	0.500	0.500	0.500	0.500	0.500	0.500	0.500	0.500	0.500	0.500	0.500	0.500
Schedule 80	0.147	0.154	0.179	0.191	0.200	0.218	0.276	0.300	0.318	0.337	0.375	0.432	0.500	0.593	0.687	0.750	0.843	0.937	1.031	1.125	1.218	-	-	-
Schedule 100	-	-	-	-	-	-	-	-	-	-	-	-	0.593	0.718	0.843	0.937	1.031	1.156	1.281	1.375	1.531	-	-	-
Schedule 120	-	-	-	-	-	-	-	-	-	0.438	0.500	0.562	0.718	0.844	1.000	1.093	1.218	1.375	1.500	1.625	1.812	-	-	-
Schedule 140	-	-	-	-	-	-	-	-	-	-	-	-	0.812	1.000	1.125	1.250	1.438	1.562	1.750	1.875	2.062	-	-	-
Schedule 160	0.187	0.218	0.250	0.250	0.281	0.343	0.375	0.438	-	0.531	0.625	0.718	0.906	1.125	1.312	1.406	1.593	1.781	1.968	2.125	2.343	-	-	-
Double Extra Strong	0.294	0.308	0.358	0.382	0.400	0.436	0.552	0.600	0.636	0.674	0.750	0.864	0.875	1.000	1.000	-	-	-	-	-	-	-	-	-